



# COMPACT 8

# COMPACT 10N

## Optimum compactness

- Width of 81 cm to operate in the most congested areas
- Compact stowed height for easy access through standard doorways

## Exceptional productivity

- Load capacity up to 350 kg (Compact 8)
- Driveable at full height
- Extended platform
- Long working cycles

## Reliable, easy to maintain





# COMPACT 8 / COMPACT 10N

## ELECTRIC SCISSOR LIFTS

### TECHNICAL DATA

#### COMPACT 8

#### COMPACT 10N

Working height	8.2 m	10 m
Platform height	6.2 m	8 m
Driveable at full height up to	6.2 m	8 m
Lift capacity - inside	350 kg	230 kg
Lift capacity - outside	120 kg	N/A
<b>A</b> Platform length - outside	2.31 m	2.31 m
<b>B</b> Platform length - extended	3.23 m	3.23 m
Length - extension	0.92 m	0.92 m
<b>C</b> Platform width - outside	0.81 m	0.81 m
<b>E</b> Storage height	1.13 m	1.32 m
<b>D</b> Height - stowed	2 m	2.18 m
<b>F</b> Overall width	0.81 m	0.81 m
<b>G</b> Length	2.49 m	2.49 m
<b>H</b> Wheelbase	1.86 m	1.86 m
<b>I</b> Ground clearance - Center	13 cm	13 cm
Ground clearance - Pothole guards deployed	2.5 cm	2.5 cm
Drive speed	1 - 3.3 km/h	1 - 3.2 km/h
Gradeability	23 %	23 %
Tilt	2 °	2 °
Lift / lower speed	26 s / 37 s	36 s / 42 s
Turning radius - outside	2.38 m	2.38 m
Non-marking tires	15x5	15x5
Batteries	24 V - 260 Ah (C20)	24 V - 260 Ah (C20)
Hydraulic system capacity	27 l	27 l
Weight	1 655 kg	2 190 kg

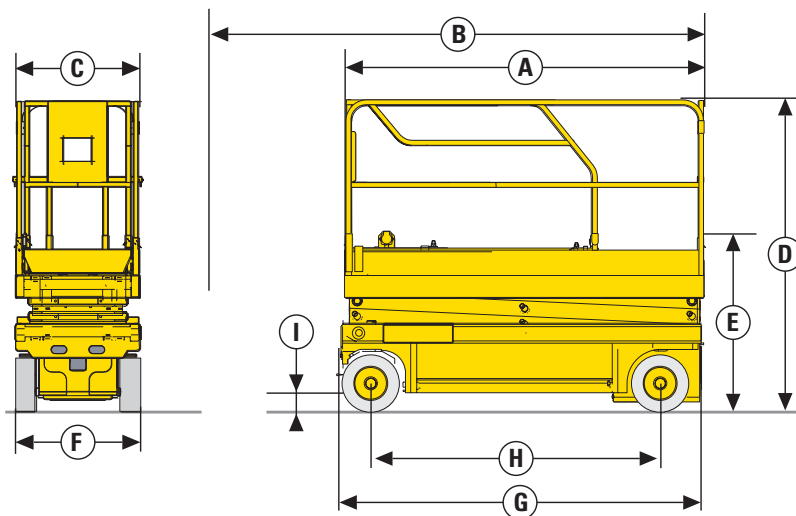

### Compact 8

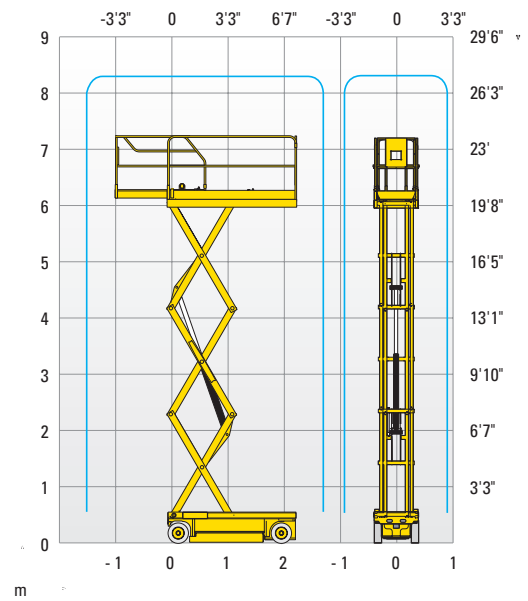

### STANDARD EQUIPMENT

- Pothole guards
- Battery charge indicator
- Proportional lift and drive
- Folding handrails (C10N)
- Swing out component tray
- Battery charger with automatic stop
- Solid non-marking tyres
- Free wheeling device
- Tilt controller
- Load Management System in the platform
- Manual platform lowering valve
- Integrated forklift pockets
- Towing hooks
- Horn
- Hourmeter

### OPTIONS AND ACCESSORIES

- Flashing light
- Travel alarm
- Working light
- Power to platform
- Biodegradable hydraulic oil
- Folding guardrails (C8)
- Centralised battery filling

