

Haulotte 
GROUP

More than lifting

La Peronnière
BP 9
42152 l'Horme
France

Tel: +33 (0)4 77 29 24 24
Fax: +33 (0)4 77 29 43 95
haulotte@haulotte.com
www.haulotte.com

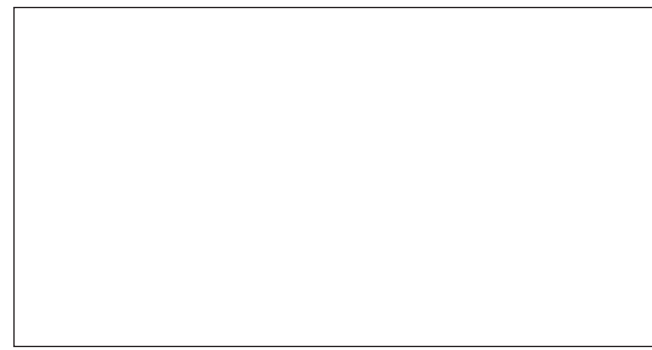

Photos: Haulotte, Fotolia, Getty Images, Maitas Antoniasst • Lovenly 10637e

HA16 RTJ

MADE FOR YOUR BUSINESS

Haulotte 

HA16 RTJ MADE FOR YOUR BUSINESS



From the very start of the project, Haulotte has been committed to working in partnership with its customers to create the **HA16 RTJ**: technical expertise combined with field experience.

EACH COMPONENT, EACH DETAIL HAS BEEN DESIGNED TO ACHIEVE AN OPTIMUM LEVEL OF PERFORMANCE.
THE **HA16 RTJ** IS ENGINEERED TO ACHIEVE 3 OBJECTIVES:
TO MAXIMIZE YOUR PRODUCTIVITY, TO LOOK AFTER YOUR BUDGET AND TO ENSURE OPERATORS' SAFETY.

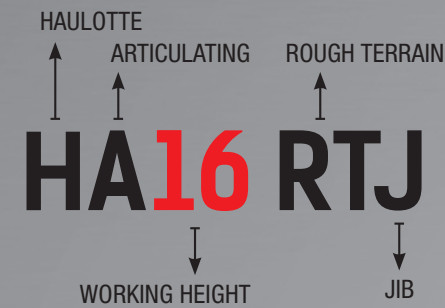

Haulotte >>>
TAKES CARE OF
YOUR BUSINESS

Haulotte >>>
TAKES CARE OF
YOUR VALUE

Haulotte >>>
TAKES CARE OF
YOUR SAFETY

“ My idea of a perfect machine: simplicity, productivity and reliability ”



Haulotte >>
**TAKES CARE OF
YOUR BUSINESS**



The new **HA16 RTJ** is more than just a machine to do a job: it's strong, fast, easy to use and highly productive.

By far the best solution for your business!

> **Results:**

- **TIME SAVING**
- **EASY TO USE**
- **EASY TO TRANSPORT**



Haulotte 
HAULOTTE TAKES CARE OF YOUR BUSINESS

1 PERFORMANCE

From productivity to acquisition costs, the **HA16 RTJ** offers the best quality / price / durability ratio. It provides a unique level of performance even in the most challenging environments.



INCREASED PRODUCTIVITY THANKS TO A SMART DESIGN

> OPTIMUM WORKING ENVELOPE

Working height: 16 m
Best horizontal outreach on the market



> EXCELLENT ALL TERRAIN CAPABILITIES

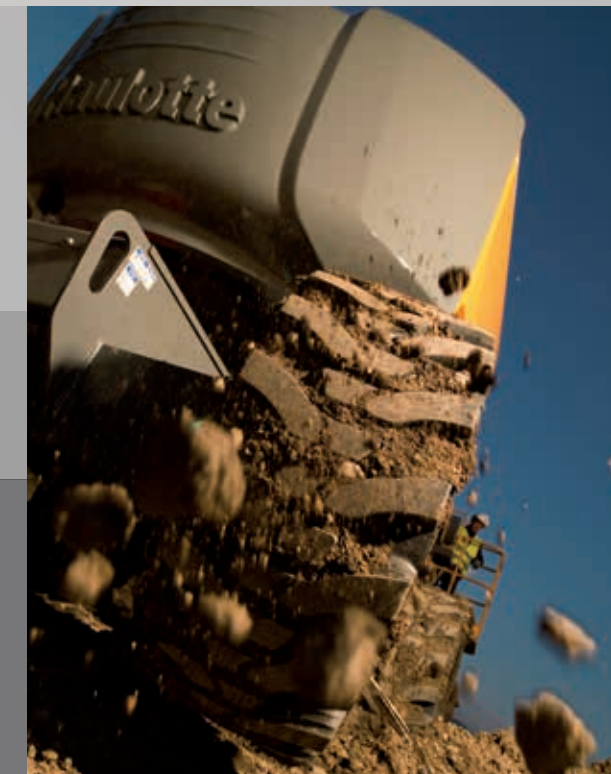

The oscillating axle (RTJ O and RTJ PRO models) increases stability on uneven ground

> OPTIMIZED WORKING TIME



Lift speed to full height:
40 seconds thanks to simultaneous movements

Permanent hydraulic differential wheel lock to evenly distribute the power to the wheels



Haulotte 
HAULOTTE TAKES CARE OF YOUR BUSINESS

2 SIMPLICITY & COMFORT

The new **HA16 RTJ** is your key partner in all situations: easy to use, it allows you to save significant working time on construction sites. Its simplicity of operation significantly improves the operator's quality of work. It's also one of the lighter models in its category. **Easier to use, more compact and easily transported,** its perfect proportions allow you to optimize your transport costs.



A HIGH LEVEL OF PRECISION

> EASE OF USE



Ergonomic upper control box allowing a more intuitive operation



Tool tray: ideal to always have the right tools at hand

> MAXIMUM COMFORT



Smooth lifting and driving: the working area is reached with maximum precision



Excellent acoustic comfort: up to **2 times** quieter!



Fuel consumption reduced by **15%**

> OPTIMIZED TRANSPORT



Economic transportation: thanks to the ability to fold the jib under the boom, one truck = 2 HA16 RTJ

“ My top priorities:
a machine that is durable,
easy to maintain
and easy to resell ”



Haulotte >>>
**TAKES CARE OF
YOUR VALUE**



The new **HA16 RTJ** is robust and designed to withstand intensive use. Each key point which is sensitive to wear has been strengthened in order to increase the machine's capabilities on all types of terrain.

> **Results:**

- **HIGH RELIABILITY**
- **MAXIMUM STRENGTH**
- **EASY MAINTENANCE**





Haulotte 
HAULOTTE TAKES CARE OF YOUR VALUE

1 DURABILITY & RELIABILITY

Designed to withstand day-to-day wear whilst retaining its performance over time, the **HA16 RTJ** offers high reliability, even in the toughest environments.



EXTREMELY DURABLE IN ALL CIRCUMSTANCES

> ANTICORROSION TREATMENT



Special treatment of the pivot pins. Lasts 3 times longer!

> PROTECTED WEIGHING SYSTEM



Protection system does not come into contact with the ground avoiding potential damage from impacts

> IMPACT-PROOF STEERING RODS



High protection ensured in all situations

> HIGH QUALITY COMPONENTS

- KUBOTA engine
- BOSCH joysticks
- Hydraulic system
 - HYDRAFORCE
 - SAUER DANFOSS
 - BOSCH
- DEUTSCH connectors...

We have chosen highly qualified and reliable suppliers who have an established network, meaning they can supply spare parts anywhere in the world





Haulotte 
HAULOTTE TAKES CARE OF YOUR VALUE

2 ROBUSTNESS

From the selection of the best components to the protection of the most exposed parts, the **HA16 RTJ** is extremely robust.



A ROBUST MACHINE WHICH STANDS THE TEST OF TIME!

> PROTECTED CONTROL BOX



The electrical connectors of the upper control box are easy to connect and offer excellent water resistance

Extremely strong tilting cover to protect upper control box

> REINFORCED HOODS



Robust turret hoods



Resistant in all conditions (on construction sites, during transportation...)

> OPTIMIZED AND WELL ORGANISED HOSE ROUTING



Close up of the hydraulic block



Close up of the boom hydraulic routing



Haulotte 
 HAULOTTE TAKES CARE OF YOUR VALUE



MAINTENANCE

Success is not just required on the construction site: maintenance is also very important. From the self-diagnostic system to easy access to all components, everything has been designed to reduce downtime.

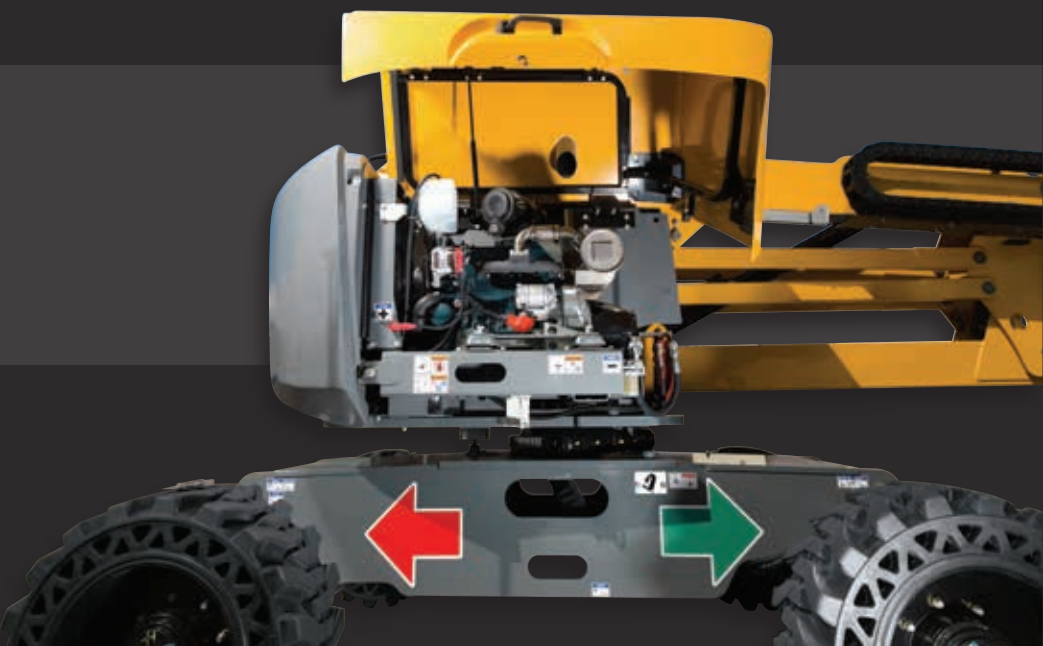

LESS MAINTENANCE, MORE WORKING TIME

➤ MODULAR ASSEMBLY



Easily removable modular hood and basket

➤ EASY ACCESSIBILITY



Swing out engine tray enabling direct access to key components

➤ EASY DIAGNOSTICS



Pre-diagnosis screen



Haulotte Diag system designed to provide a complete and immediate diagnosis, in the workshop or on-site

“ The safety of my employees on the construction site is my number one priority ”



Haulotte 
**TAKES CARE OF
YOUR SAFETY**

The new **HA16 RTJ** offers the highest innovation regarding your workers' safety. It protects your operators on the construction site without compromising productivity.

► **Results:**

- **SAFE DRIVING**
- **PEACE OF MIND**

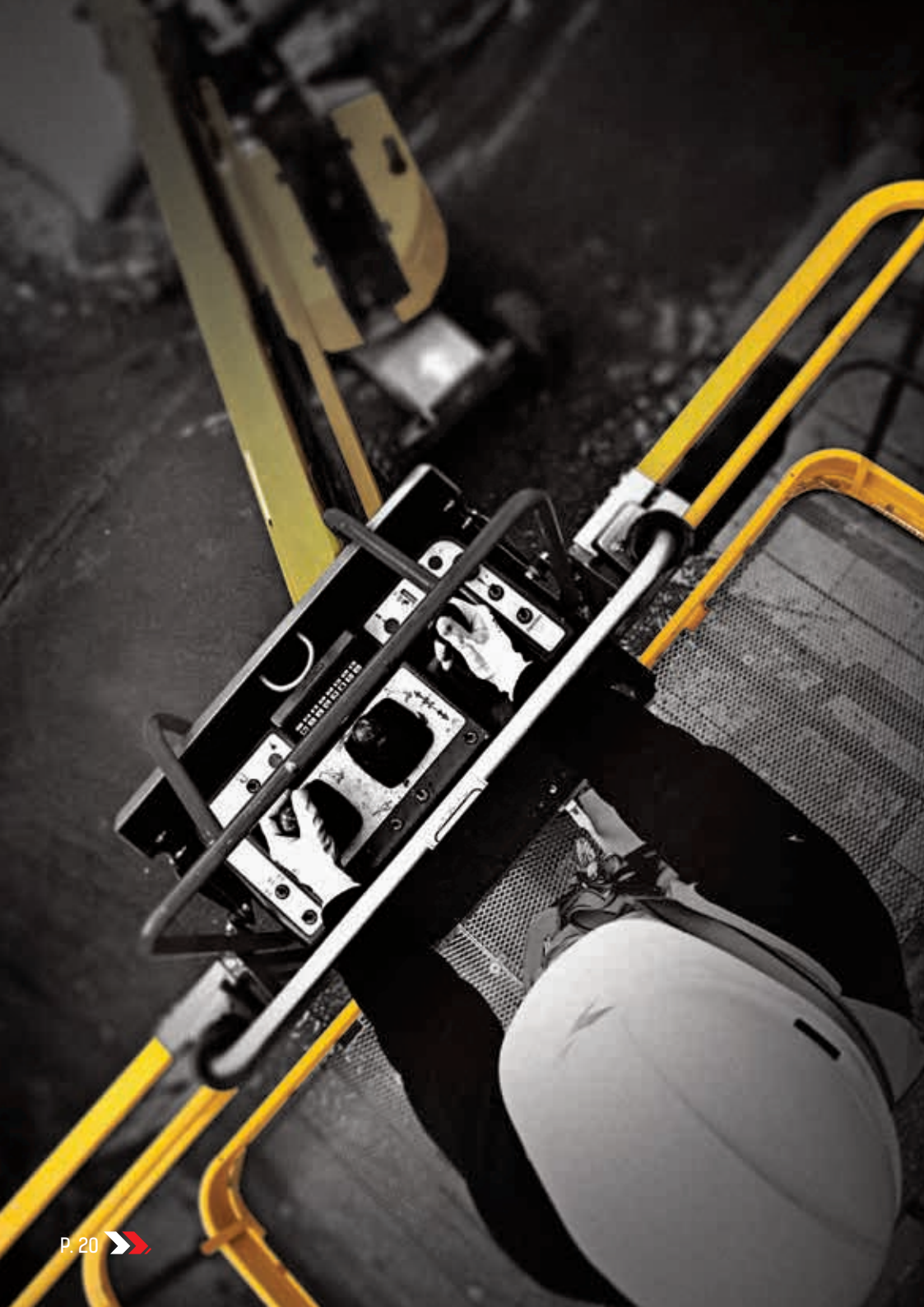

Haulotte 
 HAULOTTE TAKES CARE OF YOUR SAFETY

1

HAULOTTE ACTIV'SHIELD® BAR

Haulotte has launched a unique secondary guarding system: HAULOTTE ACTIV'Shield® Bar reduces crushing risks while maintaining excellent productivity.

This equipment was designed to meet an increasing demand from the construction industry, and reaffirms Haulotte's commitment to safe working at height.

HAULOTTE ACTIV'Shield® Bar is standard on the **HA16 RTJ PRO** and available as an option on the **RTJ** and **RTJ O** models.



Haulotte
ACTIV'SHIELD® BAR

SAFETY INNOVATION BY HAULOTTE

➤ **SAFETY GAP™**

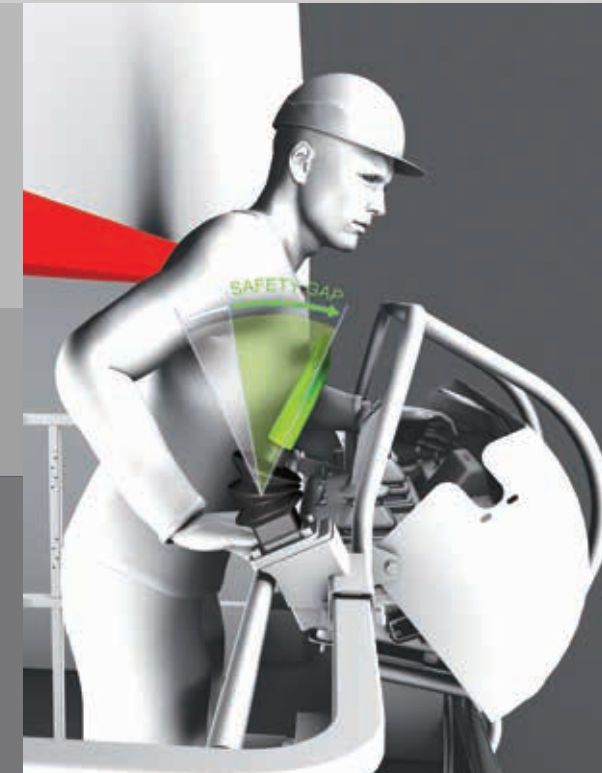

The removable bar provides an additional safety margin to protect workers from any risk of crushing

➤ **ACTIVE TECHNOLOGY PROTECTION**

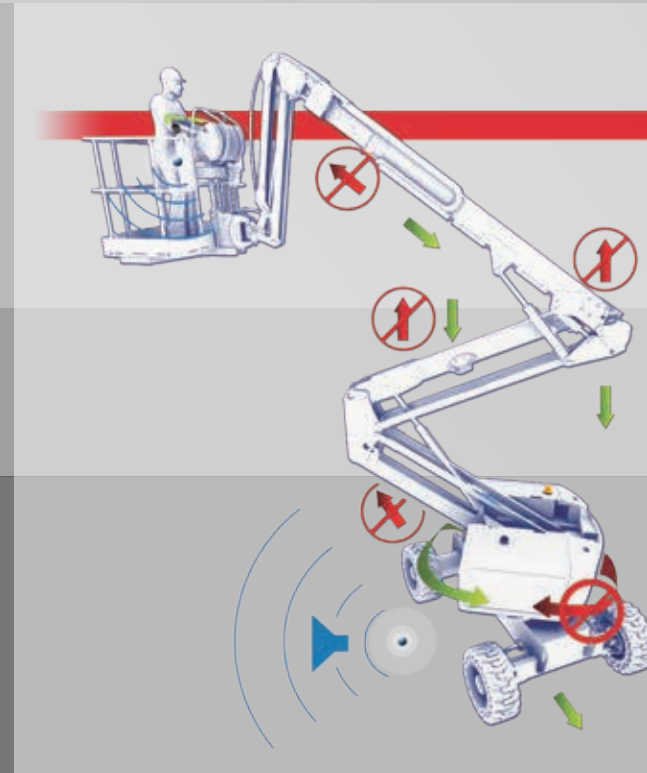

Automatic activation of the integrated alarm system when a risk of crushing is detected
 When the alarm is activated, only reverse and lowering movements are allowed

➤ **EASY SYSTEM RESET**



The system reset can be operated from the basket. Zero downtime!

"Having tested and presented HAULOTTE ACTIV'Shield® Bar to a number of our key customers and Health and Safety Officers, it is clear that Haulotte ACTIV'Shield® Bar does achieve this objective of improving safety whilst working at height."

Philip JAMES,
 Managing Director of UK Platforms Ltd part of HSS Group



Haulotte 
HAULOTTE TAKES CARE OF YOUR SAFETY

SAFE DRIVING

The **HA16 RTJ** feels exceptionally safe to drive thanks to its smooth movements. Its many features make it a reliable and safe machine in any situation.



SAFE AND EFFECTIVE DRIVING IN ALL CONDITIONS

- > **EXCELLENT MANOEUVRABILITY**
- > **MAXIMUM VISIBILITY**
- > **OSCILLATING AXLE**



When driving, the joystick can be operated with only one hand, so the other can hold the safety rail



Drive at maximum speed with the jib in an elevated position allowing excellent visibility of the working area

- > **BOOM RIGIDITY**



Optimum stability: the boom doesn't flex and the basket doesn't sway



On the RTJ 0 and RTJ PRO models, the oscillating axle allows the 4 wheels to maintain contact with the ground at all times

HA16 RTJ MADE FOR ALL APPLICATIONS

The HA16 RTJ is a multipurpose machine that suits many types of application.

BUILDING WORKS

Steelwork, curtain walls, cladding, masonry, sandblasting, painting...

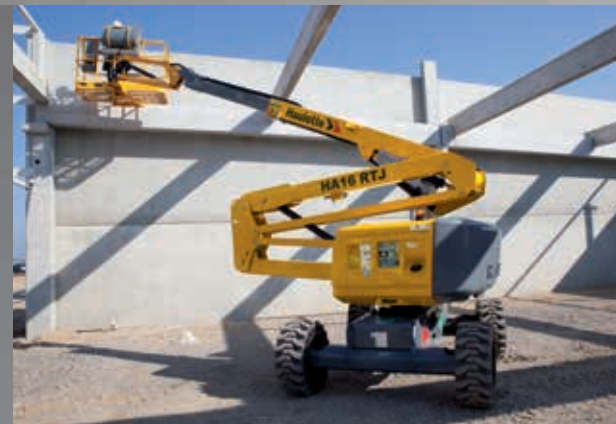

FINISHINGS

Plumbing, electrics, air conditioning heating, insulation...



DEMOLITION



MAINTENANCE

Plumbing, electrics, air conditioning heating, insulation, industrial cleaning...



LANDSCAPING AND TREE SURGERY

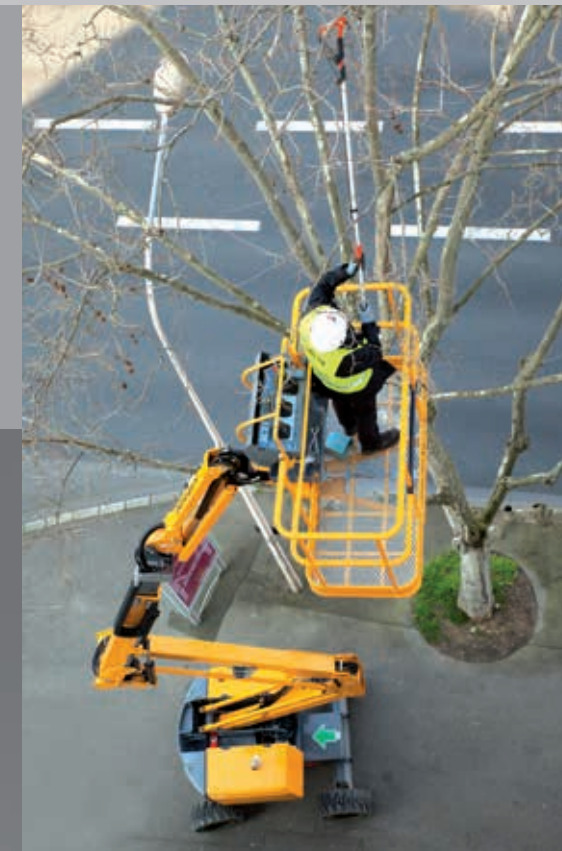

SPORTING AND OTHER EVENTS

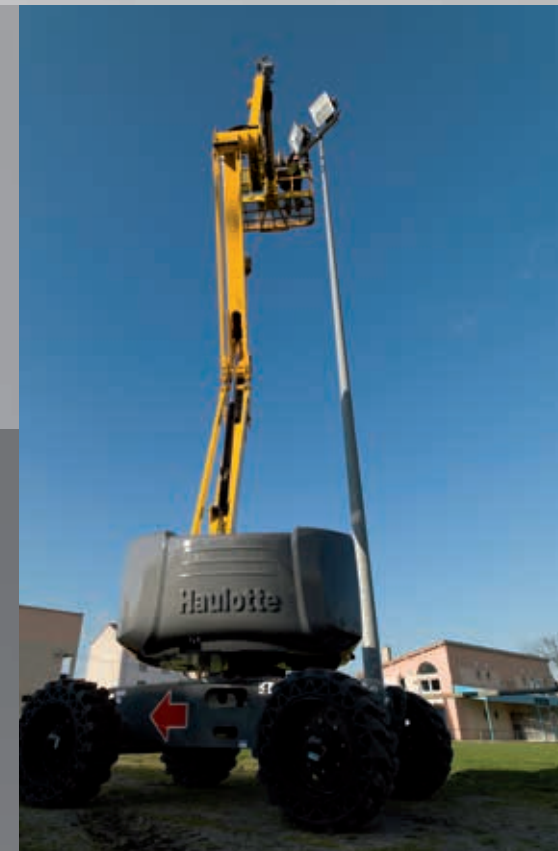

HA16 RTJ 3 BASIC MODELS

Haulotte offers 3 basic models, providing a machine perfectly suited for all your needs and your working conditions.

HA16 RTJ

- Jib
- 2 wheel steer
- 355° rotating turret



HA16 RTJ O

- Jib
- 2 wheel steer
- 355° rotating turret
- Oscillating axle

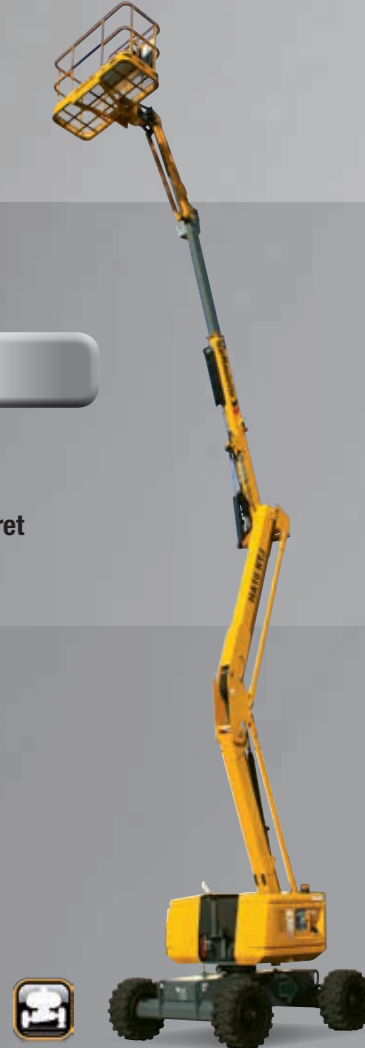

HA16 RTJ PRO

- Jib
- 4 wheel steer
- 360° rotating turret
- Oscillating axle
- HAULOTTE ACTIV'Shield® Bar



MANY OPTIONS AVAILABLE

Key options available to meet your requirements:

> VISIBILITY

- 70W working light
- Flashing light

> PRODUCTIVITY

- Power to platform
- Air-line to platform
- Modular large basket 2.44 x 0.91m
- Lateral swing door entry gate
- 360° rotating turret (Available as an option on the RTJ O model / Standard on the RTJ PRO model)
- Hydraulic generator 3.5kW
- Large cured on solid rough terrain tires (Available as an option on the RTJ O and RTJ PRO models)
- Non-marking tires

> SAFETY

- HAULOTTE ACTIV'Shield® Bar (Available as an option on the RTJ and RTJ O models / Standard on the RTJ PRO model)

> CLIMATE AND ENVIRONMENT

- Cold weather kit: -10°C / -25°C
- Hot weather kit: hydraulic oil + hydraulic oil cooler
- Biodegradable hydraulic oil

